

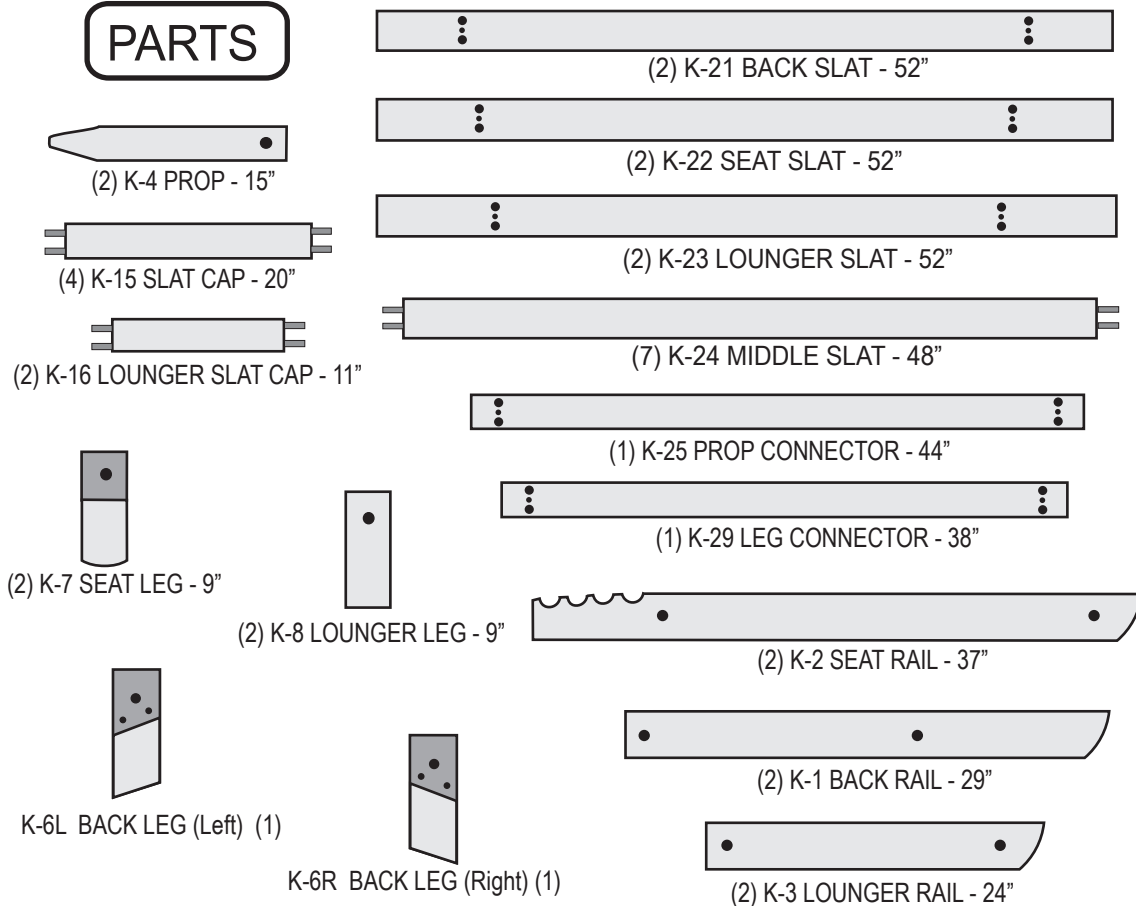

# Instructions for Trifold Lounger Full #7832

PARTS LIST					
K-1	BACK RAIL	2	K-16	11" LOUNGER SLAT CAPS	2
K-2	SEAT RAIL	2	K-24	MIDDLE SLATS	7
K-3	LOUNGER RAIL	2	K-21	BACK SLATS	2
K-4	PROP	2	K-22	SEAT SLATS	2
K-25	PROP CONNECTOR	1	K-23	LOUNGER SLATS	2
K-6	BACK LEG (Left and Right)	2	H-8	2-1/4" CLEVIS PIN	4
K-7	SEAT LEG	2	H-12	3" CLEVIS PIN	4
K-8	LOUNGER LEG	2	H-5	HAIR PIN	8
K-29	LEG CONNECTOR	1	H-6	WASHER	8
K-15	20" SLAT CAPS	4	H-11	WOOD DOWEL	32
			H-19	WOOD SCREW	20

## PARTS



1

Use a small hammer to tap Wood Dowels (H-11) all the way into holes as shown.

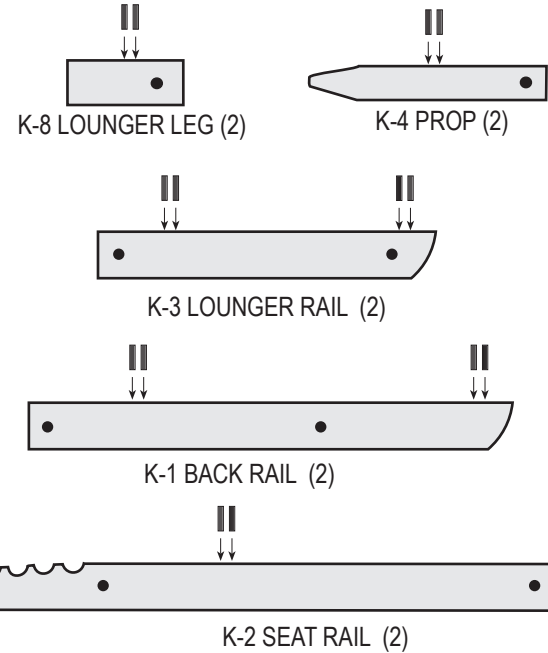

2

Press the Prop Connector (K-25) onto the Wood Dowels on the Props (K-4) and attach with Wood Screws (H-19).

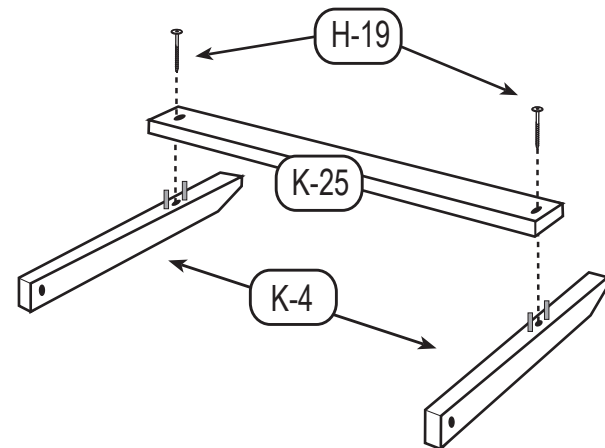

**3**

Be sure that the Prop Connector goes below the Back Rails.

H-8

H-5

H-6

K-1

H-8

Attach the Back Rails (K-1) to the outside of the Prop Assembly using 2-1/4" Clevis Pins (H-8). Let the Prop Assembly swing down so that the Prop Connector can go below the Back Rails as shown. Secure the Clevis Pins with Washers (H-6) and Hair Pins (H-5).

**5**

Attach the Left and Right Back Legs (K-6) to the outside of the Back Rails using the 3-1/4" Clevis Pins (H-12). Do not put on the Washers and Hair Pins at this time.

H-12

K-6R

H-12

K-6L

Make sure that the cut-away part of the Back Legs face in so that they will support the Back Rails.

**4**

Please double-check your work at this time. Any error in this assembly will cause serious problems later.

Be sure that the Prop Connector is below the Back Rails.

Be sure that the Props are on the inside of the Back Rails.

**6**

First, place the Seat Rails (K-2) onto the 3" Clevis Pins and secure with Washers (H-6) and Hair Pins (H-5).

Second, secure the Back Legs with Wood Screws (H-19). (These screws are self-tapping and do not need pilot holes.)

H-19

K-2

H-19

K-2

Note: Look for the labels "THIS SIDE FACES IN" on the Seat Rails (K-2) and install them on the correct side.

7

Attach the Seat Legs (K-7) and the Lounger Rails (K-3) to the Seat Rails using 3" Clevis Pins (H-12). Secure the Clevis Pins with Washers (H-6) and Hair Pins (H-5).

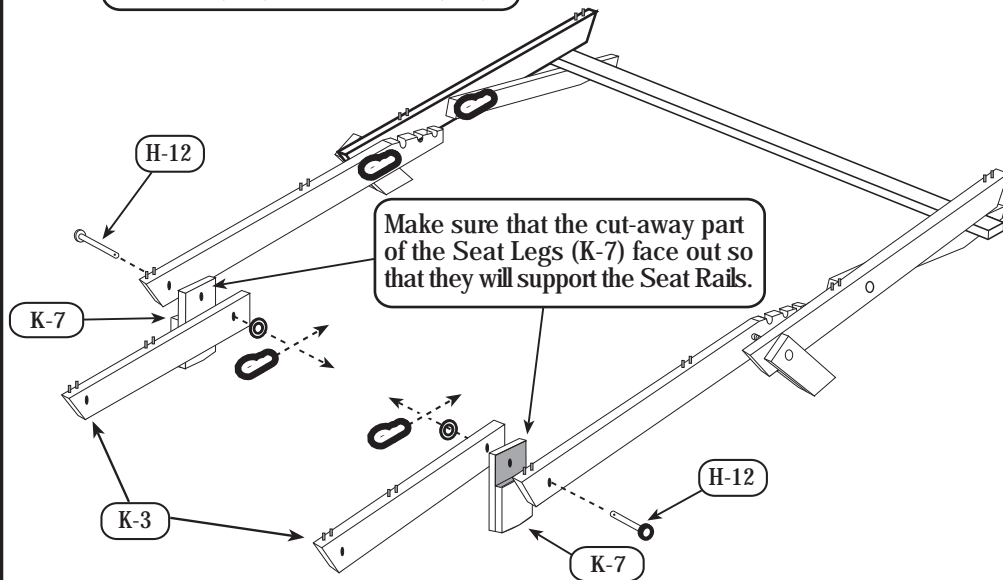

8

Attach the Lounger Legs (K-8) to the Lounger Rails using 2-1/4" Clevis Pins (H-8) and secure with Washers and Hair Pins. Then push the Leg Connector (K-29) onto the Wood Dowels on the Lounger Legs and attach with Wood Screws (H-19).

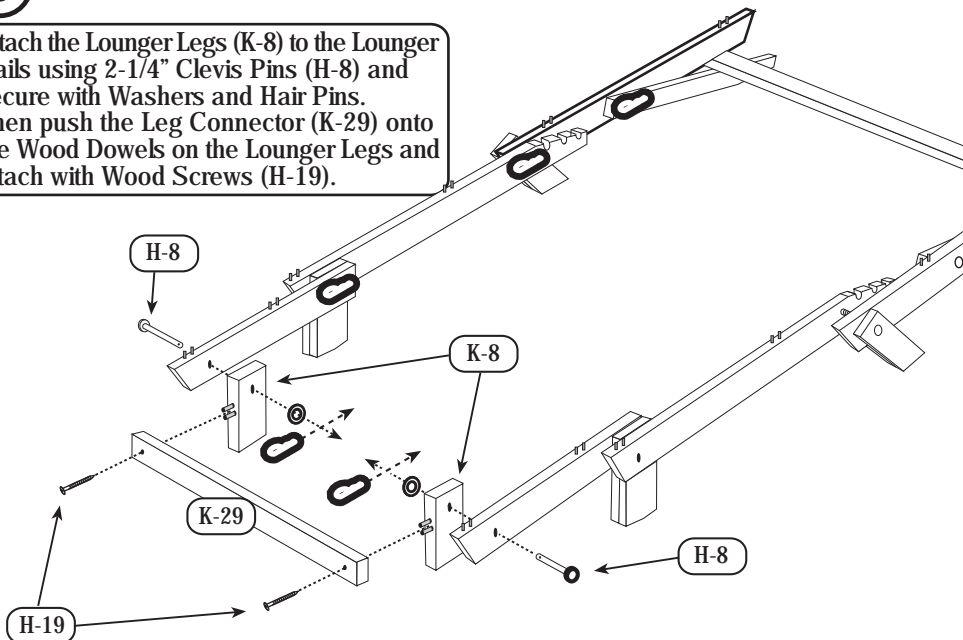

9

Using (3) Middle Slats (K-24) push the Wood Dowels into the edge holes on (2) Slat Caps (K-15).

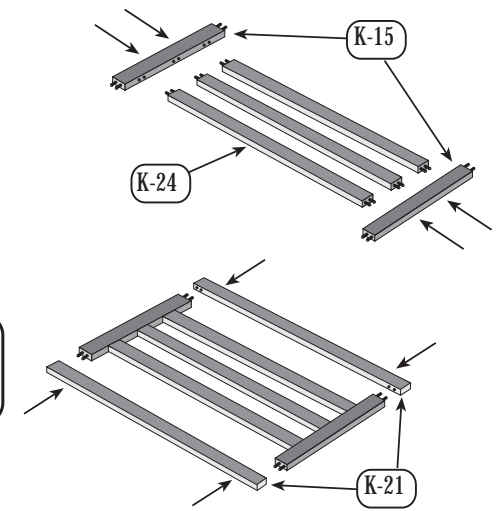

Find the (2) Back Slats (K-21) and push them onto the Wood Dowels on the Slat Caps.

10

Using (3) Middle Slats (K-24) push the Wood Dowels into the edge holes on (2) Slat Caps (K-15).

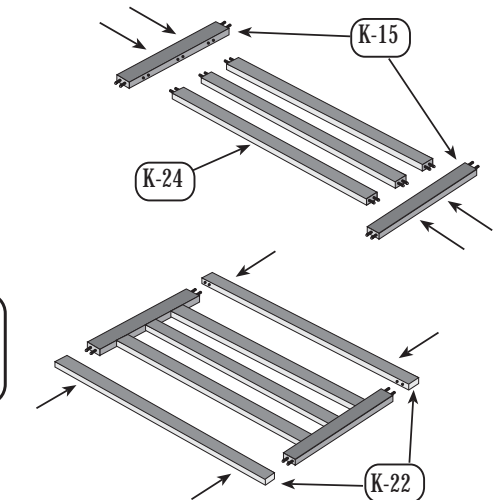

Find the (2) Seat Slats (K-22) and push them onto the Wood Dowels on the Slat Caps.

11

Use (1) Middle Slat (K-24) and push the Wood Dowels into the edge holes on (2) Lounger Slat Caps (K-16).

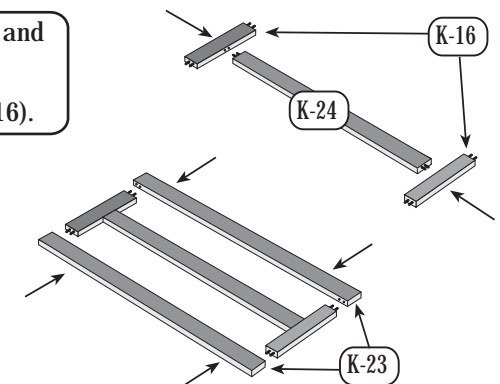

Find the (2) Lounger Slats (K-23) and push them onto the Wood Dowels on the Lounger Slat Caps.

12

Push the Slat Decks down onto the Wood Dowels and attach with Wood Screws (H-19).

Note: Wood Screws are self-tapping and do not need pilot holes.

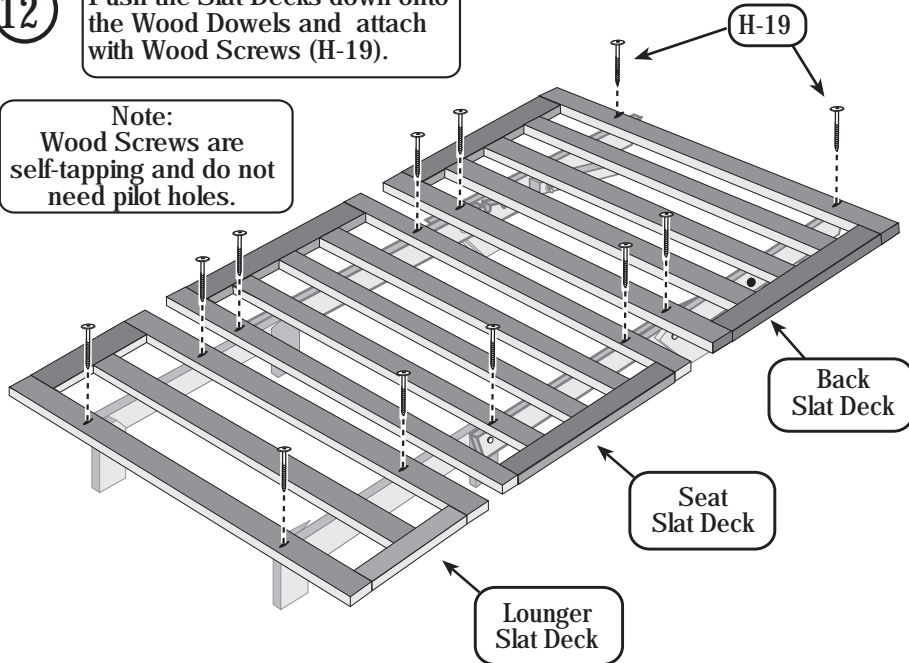

This futon frame is made with Tulip Poplar. Any green tint in the wood will change to light brown in a few weeks. This will happen in 20 to 30 minutes if placed in direct sunlight. Tulip Poplar can be left unfinished, clear finished, stained, or painted. I prefer the lighter stains over the darker ones because the wood is fairly porous. My favorite is a clear finish with no stain. Satin polyurethane (oil or water based) works well.

Painting: It is best to start with an interior primer and lightly sand before painting.

Staining: Lightly sand before staining. Wipe stain on with a rag until you get the desired color. If you are going to use a top coat (such as polyurethane), do not sand again until after the first coat, and then be careful not to sand away the stain.

Finishing: All finishes work well with Tulip Poplar. A simple wax finish over stain (Minwax for example) is easy. An oil finish such as Danish oil can be used. Or a clear top coat such as polyurethane works well to seal the wood. With polyurethanes, the first coat acts as a sanding sealer. So you should lightly sand (180 - 220 grit sandpaper) after the first coat, wipe the wood clean, and then build up coats for the desired effect.

Knockdown Frameworks, Inc. warrants all of its products for five years against any defects that are due to faulty materials or workmanship. We will promptly correct such defects by repair or replacement, at our option, without charge. This warranty covers product defects only and will expire five years after date of purchase by the original consumer purchaser, with proof of purchase required.

This warranty does not apply to damage caused by and resulting from misuse, neglect, accident, or improper operation, maintenance, storage, transportation, or handling of the product. This warranty is for the original consumer purchaser for residential use only and does not apply if the product is used in any commercial application (such as rental property). This warranty does not cover any incidental or consequential damages. If you feel that you have a claim under this warranty, please contact the store from which it was purchased. If this is not possible, call 800-543-3393 for advice on handling your claim.

# Operation:

Bed position:



Lounger position with footrest flat:

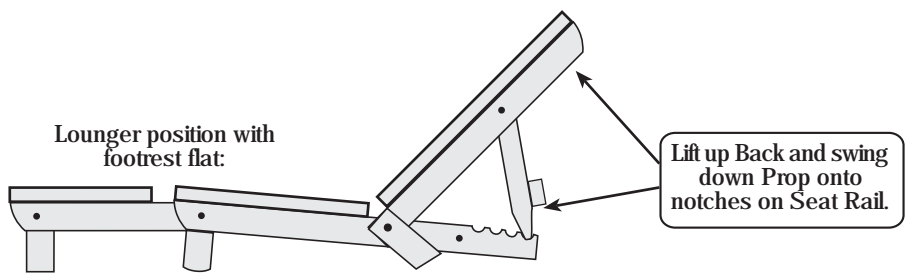

Lounger position with footrest down:

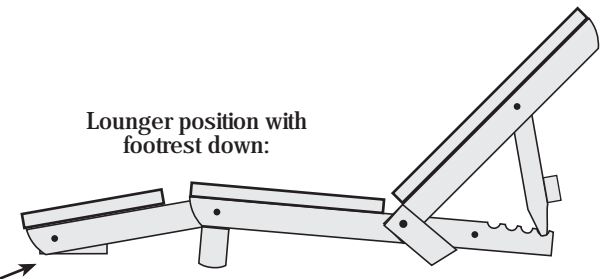

Sofa position:

